



MG75HF12TLC1 □

IGBT Modules

V_{CES}	1200V
I_c	75A

Applications

Inverter for motor drive
AC and DC servo drive amplifier
UPS (Uninterruptible Power Supplies)
Soft switching welding machine

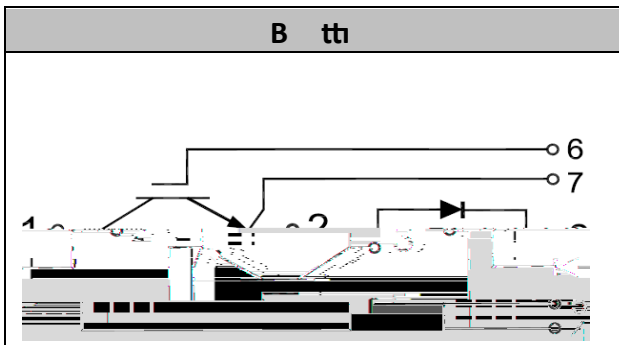

Features

Low $V_{ce(sat)}$ with Trench technology
 $V_{ce(sat)}$ with positive temperature coefficient
High short circuit capability(10us)
Including ultra fast & soft recovery anti-parallel FWD
Low inductance
Maximum junction temperature 175

● IGBT

Absolute Maximum Ratings

Parameter	Symbol	Conditions	Value	Unit
Collector-Emitter Voltage	V_{CES}	$V_{GE}=0V, I_c = 1mA, T_{vj}=25$	1200	V
Continuous Collector Current	I_c	$T_c=100$	75	A
Repetitive Peak Collector Current	I_{CRM}	$t_p=1ms$	150	A
Gate-Emitter Voltage	V_{GES}	$T_{vj}=25$	20	V
Total Power Dissipation	P_{tot}	$T_c=25$ $T_{vjmax}=175$	530	W



MG75HF12TLC1 □

Characteristic values

Parameter	Symbol	Conditions	Value			Unit
			Min.	Typ.	Max.	

Gate-emitter ThreETO .48 0.48 ref2



MG75HF12TLC1 □

● Diode

Absolute Maximum Ratings

Parameter	Symbol	Conditions	Value	Unit
Repetitive Peak Reverse Voltage	V_{RRM}	$T_{vj}=25$	1200	V
Continuous DC Forward Current	I_F		75	A
Repetitive Peak Forward Current	I_{FRM}	$t_p=1ms$	150	A

Characteristic values

Parameter	Symbol	Conditions	Value			Unit
			Min.	Typ.	Max.	
Forward Voltage	V_F	$I_F=75A, T_{vj}=25$		2.10		V
		$I_F=75A, T_{vj}=125$		2.00		
Recovered Charge	Q_{rr}	$I_F=75A$		4.8		μC
Peak Reverse Recovery Current	I_{rr}	$V_R=600V$ $-di_F/dt=1200A/\mu s$		60		A
Reverse Recovery Energy	E_{rec}	$T_{vj}=25$		3.8		mJ
Recovered Charge	Q_{rr}	$I_F=75A$		10.2		μC
Peak Reverse Recovery Current	I_{rr}	$V_R=600V$ $-di_F/dt=1200A/\mu s$		77		A
Reverse Recovery Energy	E_{rec}	$T_{vj}=125$		5.7		mJ



MG75HF12TLC1 □

● Module Characteristics

$T_c=25^{\circ}\text{C}$ unless otherwise specified

Parameter	Symbol	Conditions	Value			Unit
			Min.	Typ.	Max.	
Isolation voltage	V_{isol}	$t=1\text{min}, f=50\text{Hz}$	2500			V
Maximum Junction Temperature	T_{jmax}				175	
Operating Junction Temperature	T_{vjop}		-40		150	
Storage Temperature	T_{stg}		-40		125	
Thermal Resistance Junction-to Case	R_{jc}	per IGBT			0.26	K/W
		per Diode			0.42	
Thermal Resistance Case-to Sink	R_{cs}	Conductive grease applied		0.05		K/W
Module Electrodes Torque	M_t	Recommended(M5)	2.5		5.0	N·m
Module-to-Sink Torque	M_s	Recommended(M6)	3.0		5.0	N·m
Weight of Module	G			150		g



MG75HF12TLC1

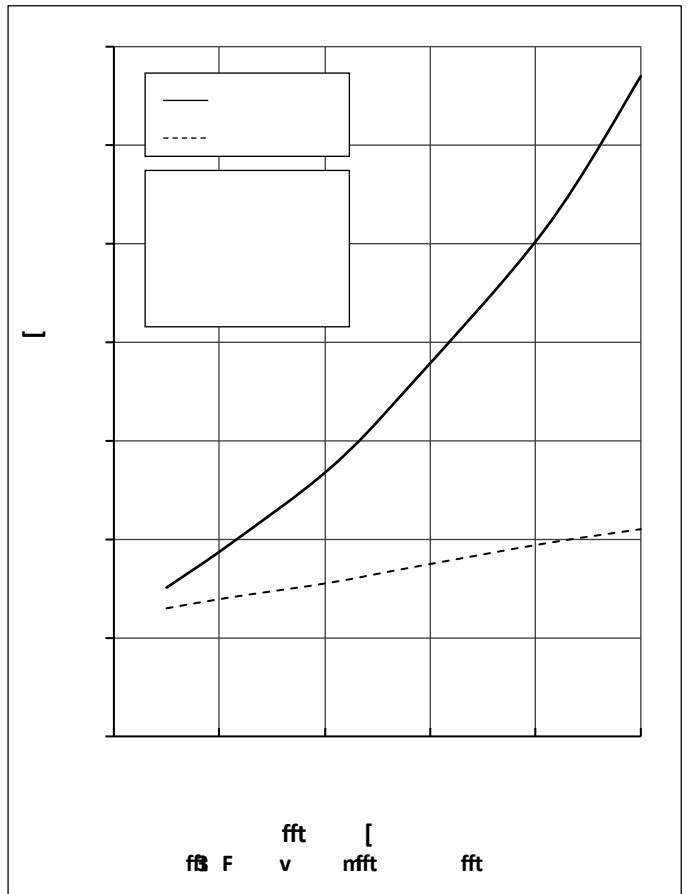
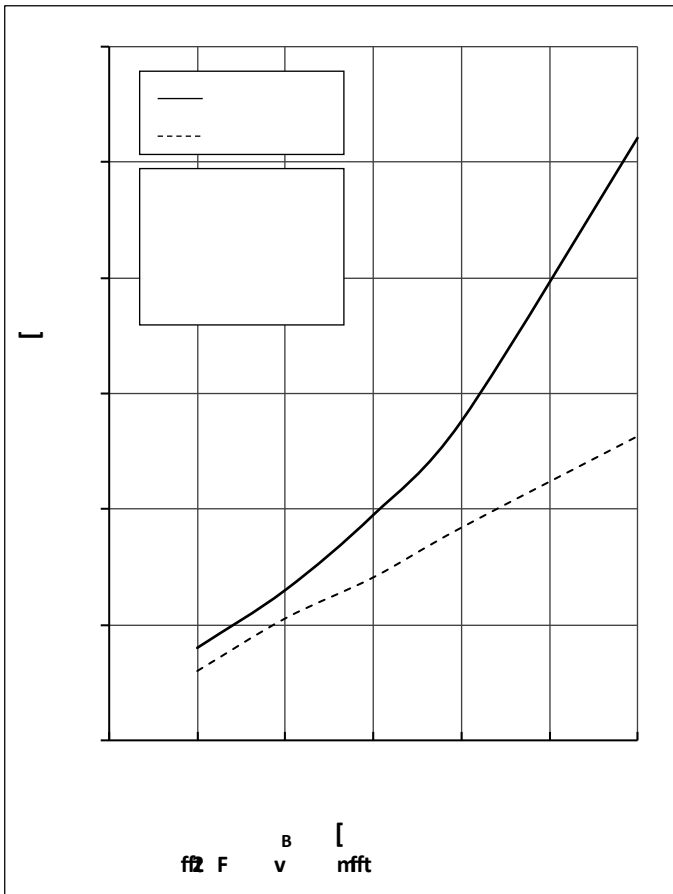
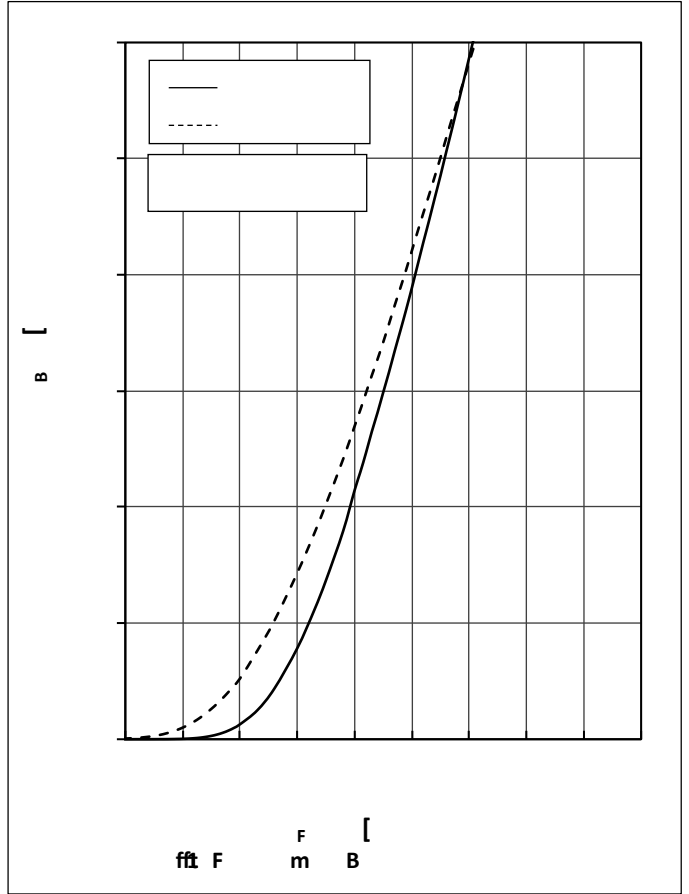
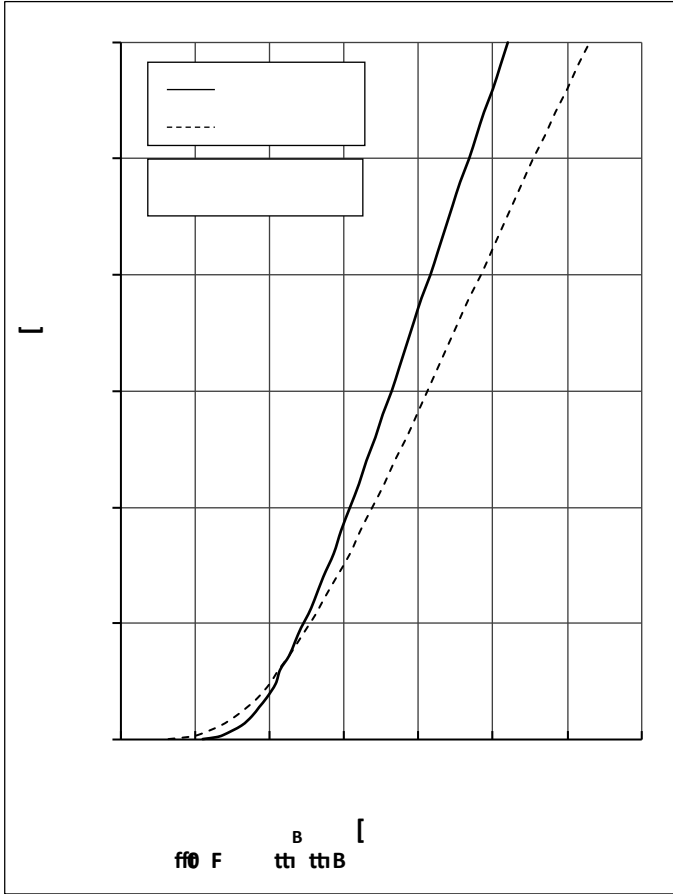



MG75HF12TLC1

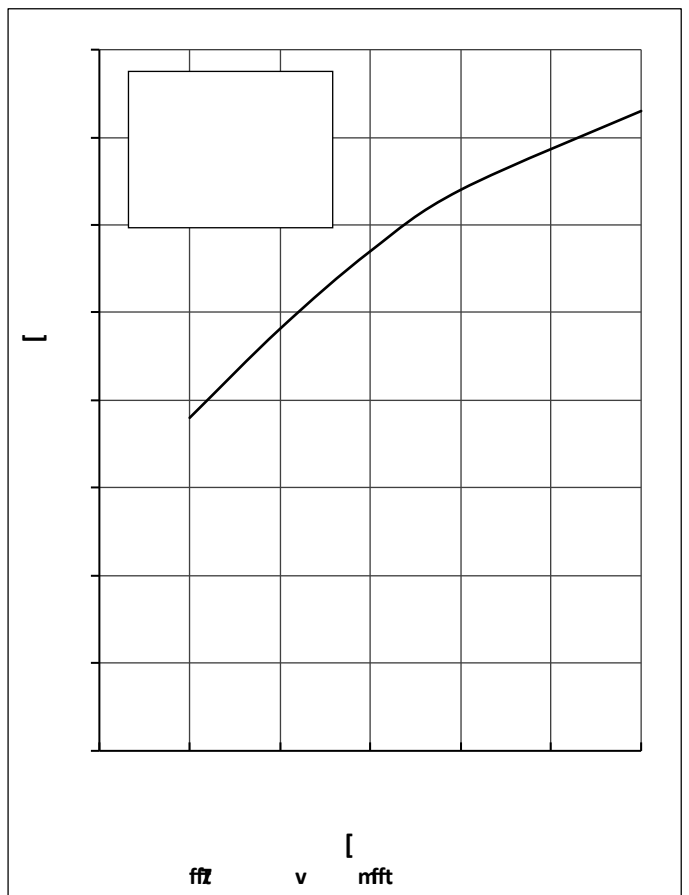
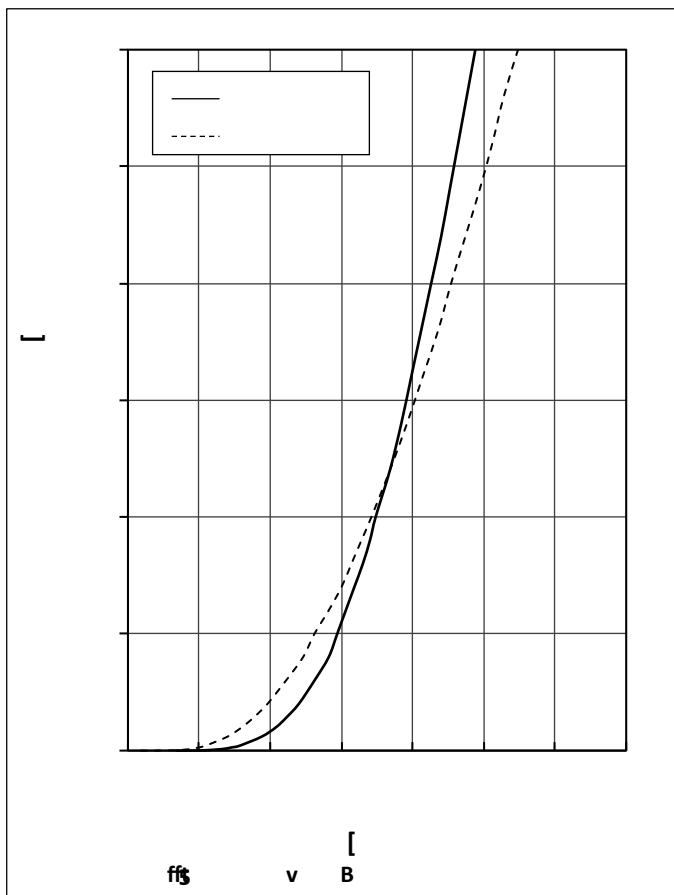
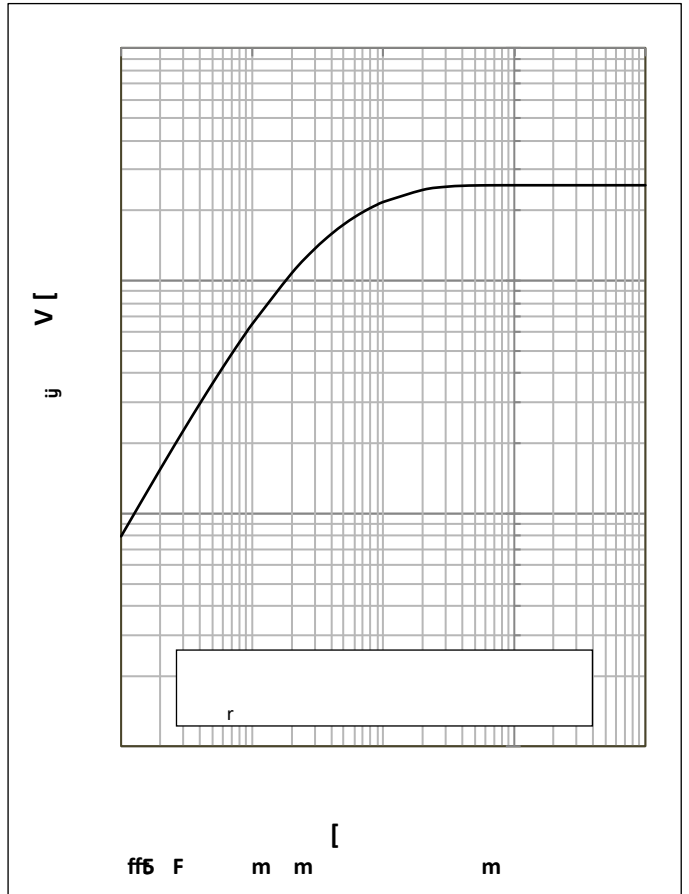
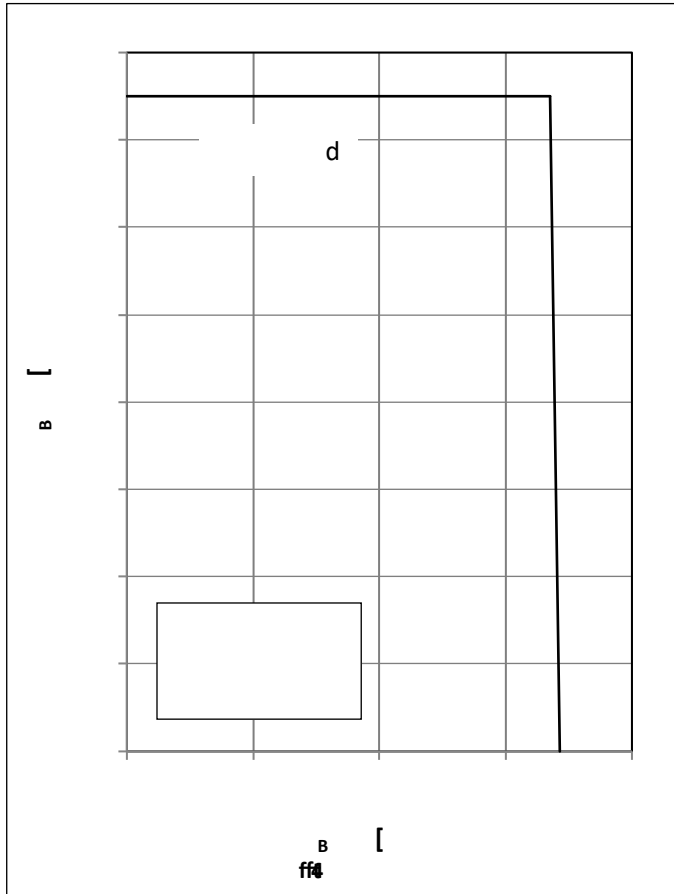



MG75HF12TLC1

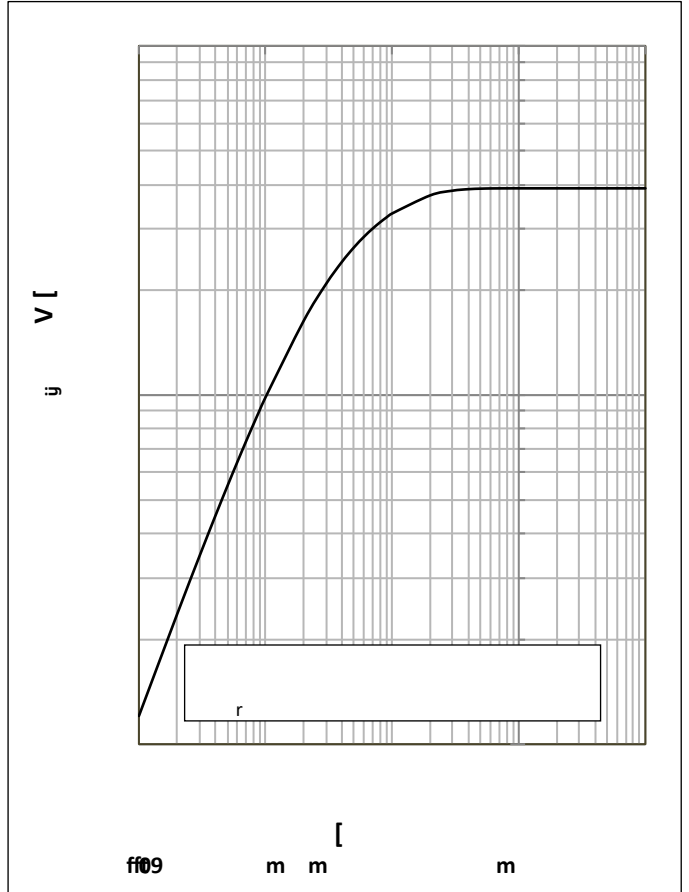
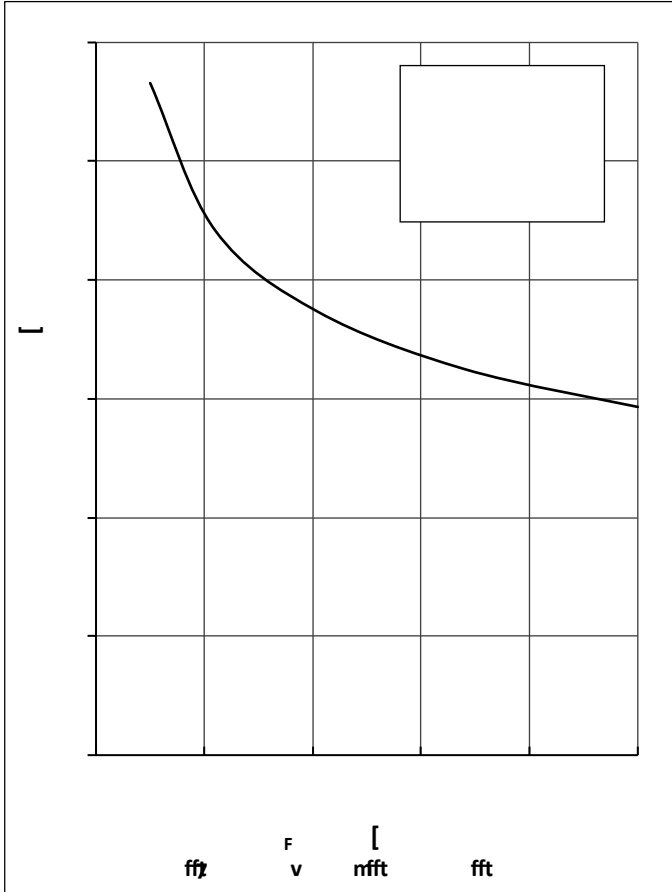



MG75HF12TLC1 □

● Circuit Diagram

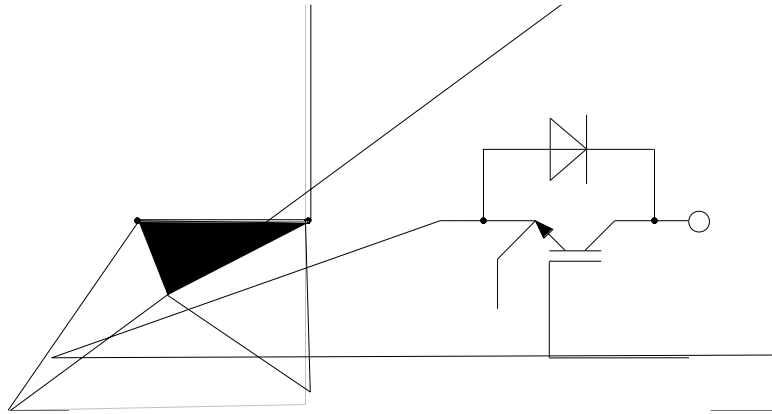

● Package Outline Information

Dimensions in Millimeters

