

1200V  
15A

Motor Drivers  
AC and DC Servo Drive Amplifier  
UPS (Uninterruptible Power Supplies)

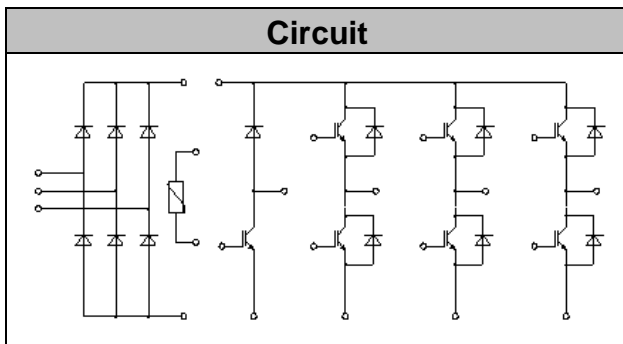

Low switching losses  
Low  $V_{CE(sat)}$  with positive temperature coefficient  
Including fast & soft recovery anti-parallel FWD  
Low inductance case  
High short circuit capability(10us)  
Isolated heatsink using DBC technology  
Maximum junction temperature 175

Collector-Emitter Voltage	$V_{CES}$	$V_{GE}=0V, I_C = 1mA, T_{vj}=25$	1200	V
Continuous Collector Current	$I_C$	$T_C=100 \quad v_{jmax} \ 175$	15	A
Repetitive Peak Collector Current	$I_{CRM}$	$t_p=1ms$	30	A
Gate-Emitter Voltage	$V_{GES}$	$T_{vj}=25$	20	V
Total Power Dissipation	$P_{tot}$	$T_C=25$ $T_{vjmax}=175$	155	W

# MG15P12P3 □

Gate-Emitter Threshold Voltage	$V_{GE(th)}$	$V_{GE}=V_{CE}, I_C=0.5mA, T_{vj}=25$	5.2	5.8	6.4	V	
Collector-Emitter Cut-off Current	$I_{CES}$	$V_{CE}=1200V, V_{GE}=0V, T_{vj}=25$			1.0	mA	
Collector-Emitter Saturation Voltage	$V_{CE(sat)}$	$I_C=15A, V_{GE}=15V, T_{vj}=25$		1.80	2.20	V	
		$I_C=15A, V_{GE}=15V, T_{vj}=125$		2.10			
		$I_C=15A, V_{GE}=15V, T_{vj}=150$		2.20			
Gate Charge	$Q_G$			0.15		uC	
Input Capacitance	$C_{ies}$	$V_{CE}=25V, V_{GE}=0V, f=1MHz, T_{vj}=25$		1.1		nF	
Reverse Transfer Capacitance	$C_{res}$			0.04		nF	
Gate-Emitter leakage current	$I_{GES}$	$V_{CE}=0V, V_{GE}=20V, T_{vj}=25$			400	nA	
Turn-on Delay Time	$t_{d(on)}$	$I_C=15A, V_{CE}=600V, V_{GE}=\pm 15V, R_G=39, T_{vj}=25$		90		ns	
Rise Time	$t_r$			64		ns	
Turn-off Delay Time	$t_{d(off)}$			180		ns	
Fall Time	$t_f$			135		ns	
Energy Dissipation During Turn-on Time	$E_{on}$			1.42		mJ	
Energy Dissipation During Turn-off Time	$E_{off}$			0.78		mJ	
Turn-on Delay Time	$t_{d(on)}$		$I_C=15A, V_{CE}=600V, V_{GE}=\pm 15V, R_G=39, T_{vj}=125$		95		ns
Rise Time	$t_r$				70		ns
Turn-off Delay Time	$t_{d(off)}$				260		ns
Fall Time	$t_f$				180		ns
Energy Dissipation During Turn-on Time	$E_{on}$			1.85		mJ	
Energy Dissipation During Turn-off Time	$E_{off}$			1.13		mJ	
SC Data	$I_{SC}$	$t_p=10\mu s, V_{GE}=15V, T_{vj}=150, V_{CC}=900V, V_{CEM}=1200V$			90		A

Repetitive Peak Reverse Voltage	$V_{RRM}$	$T_{vj}=25$	1200	V
Continuous DC Forward Current	$I_F$		15	A
Repetitive Peak Forward Current	$I_{FRM}$	$t_p=1ms$	30	A
I <sup>2</sup> t-value	I <sup>2</sup> t	$V_R=0V, t_p=10ms, T_{vj}=125$	16.0	A <sup>2</sup> s
		$V_R=0V, t_p=10ms, T_{vj}=150$	14.0	

Forward Voltage	$V_F$	$I_F=15A, T_{vj}=25$		2.00	2.65	V
		$I_F=15A, T_{vj}=125$		2.10		
		$I_F=15A, T_{vj}=150$		2.10		
Recovered Charge	$Q_{rr}$	$I_F=15A$		1.20		uC
Peak Reverse Recovery Current	$I_{rr}$	$V_R=600V$ $-di_F/dt=600A/us$		13.0		A
Reverse Recovery Energy	$E_{rec}$	$T_{vj}=25$		0.37		mJ
Recovered Charge	$Q_{rr}$	$I_F=15A$		2.05		uC
Peak Reverse Recovery Current	$I_{rr}$	$V_R=600V$ $-di_F/dt=600A/us$		12.0		A
Reverse Recovery Energy	$E_{rec}$	$T_{vj}=125$		0.68		mJ

# MG15P12P3 □

Collector-Emitter Voltage	$V_{CES}$	$V_{GE}=0V, I_C=1mA, T_{vj}=25$	1200	V
Continuous Collector Current	$I_C$	$T_C=100$ $v_{jmax}$ 175	15	A
Repetitive Peak Collector Current	$I_{CRM}$	$t_p=1ms$	30	A
Gate-Emitter Voltage	$V_{GES}$	$T_{vj}=25$	20	V
Total Power Dissipation	$P_{Tot}$	$T_C=25$ , $T_{vjmax}=175$	155	W

Gate-emitter Threshold Voltage	$V_{GE(th)}$	$V_{GE}=V_{CE}, I_C=0.5mA, T_{vj}=25$	5.2	5.8	6.4	V
Collector-Emitter Cut-off Current	$I_{CES}$	$V_{CE}=1200V, V_{GE}=0V, T_{vj}=25$			1.0	mA
Collector-Emitter Saturation Voltage	$V_{CE(sat)}$	$I_C=15A, V_{GE}=15V, T_{vj}=25$		1.85	2.25	V
		$I_C=15A, V_{GE}=15V, T_{vj}=125$		2.15		
		$I_C=15A, V_{GE}=15V, T_{vj}=150$		2.25		
Gate Charge	$Q_G$			0.09		uC
Input Capacitance	$C_{ies}$	$V_{CE}=25V, V_{GE}=0V,$ $f=1MHz, T_{vj}=25$		1.35		nF
Reverse Transfer Capacitance	$C_{res}$			0.08		nF
Gate-Emitter leakage current	$I_{GES}$	$V_{CE}=0V, V_{GE}=20V, T_{vj}=25$			400	nA
Turn-on Delay Time	$t_{d(on)}$	$I_C=15A$ $V_{CE}=600V$ $V_{GE}=\pm 15V$ $R_G=39$ $T_{vj}=25$		46		ns
Rise Time	$t_r$			45		ns
Turn-off Delay Time	$t_{d(off)}$			182		ns
Fall Time	$t_f$			168		ns
Energy Dissipation During Turn-on Time	$E_{on}$			0.92		mJ
Energy Dissipation During Turn-off Time	$E_{off}$			0.56		mJ



# MG15P12P3 □

---

Turn

# MG15P12P3 □

Repetitive Peak Reverse Voltage	$V_{RRM}$	$T_{vj}=25$	1600	V
Average output Current 50/60Hz, sine wave	$I_{F(AV)}$	$T_C=100$	20	A
Maximum RMS Current at Rectifier Output	$I_{RMSM}$	$T_C=100$	40	A
Surge Forward Current	$I_{FSM}$	$V_R=0V, t_p=10ms, T_{vj}=45$	270	A
$I^2t$ -value	$I^2t$	$V_R=0V, t_p=10ms, T_{vj}=45$	360	$A^2s$

Diode Forward Voltage	$V_F$	$I_F=15A, T_{vj}=150$	0.96	V
Reverse Current	$I_R$	$T_{vj}=150, V_R=1600V$	1.0	mA

Rated Resistance	$R_{25}$		5.0	k	
Deviation of R100	R/R	$T_C=100, R_{100}=493.3$	-5	5	%
Power Dissipation	$P_{25}$		20.0	mW	
B-value	$B_{25/50}$	$R_2=R_{25}\exp[B_{25/50}(1/T_2-1/(298.15 K))]$	3375	K	

# MG15P12P3 □

Isolation Voltage	$V_{isol}$	$t=1\text{min}, f=50\text{Hz}$	2500			V
Maximum Junction Temperature	$T_{jmax}$				175	
Operating Junction Temperature	$T_{jop}$		-40		150	
Storage Temperature	$T_{stg}$		-40		125	
Stray-inductance-module	$L_{SCE}$			30		

Module lead resistance,  
terminals-chip

$R_{CC+EE}$

$T_C=25$

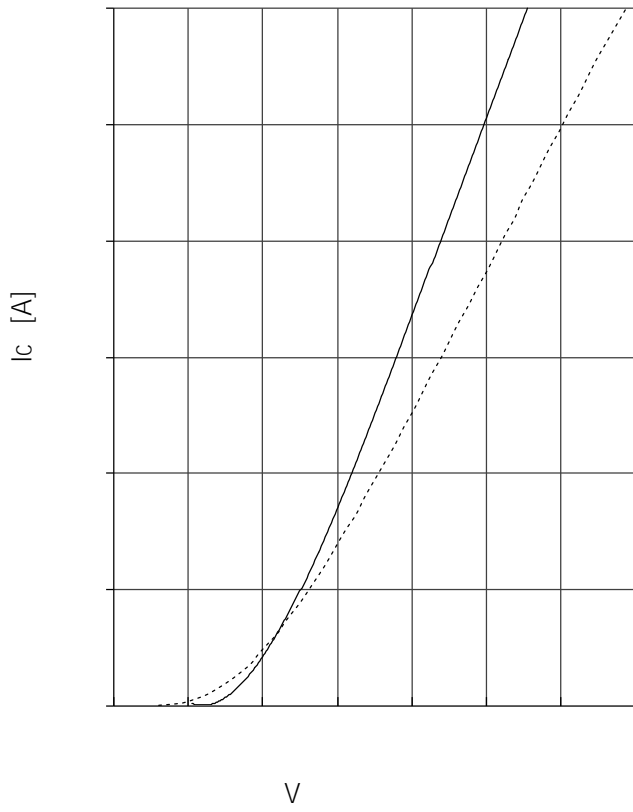



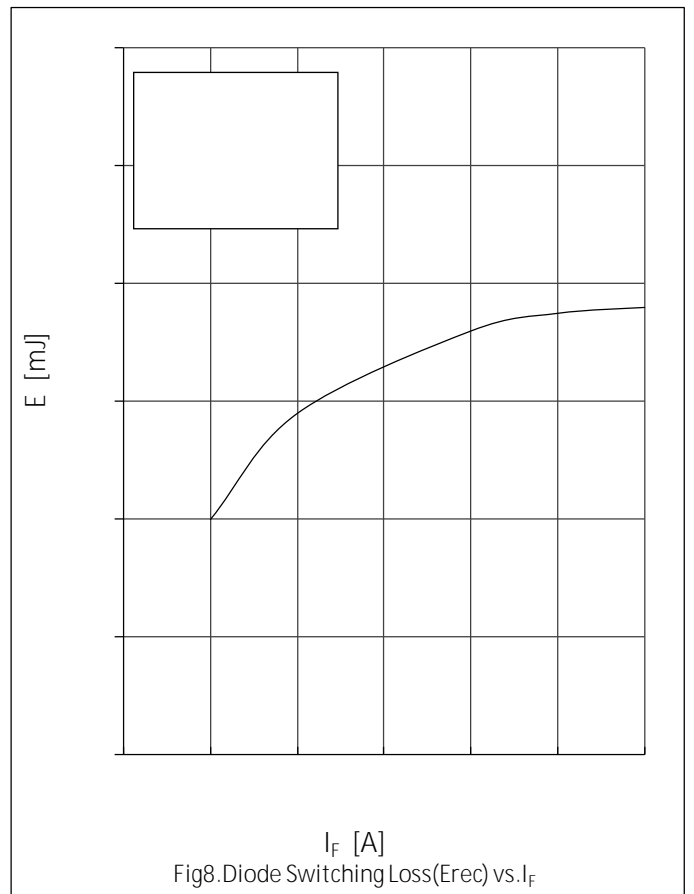
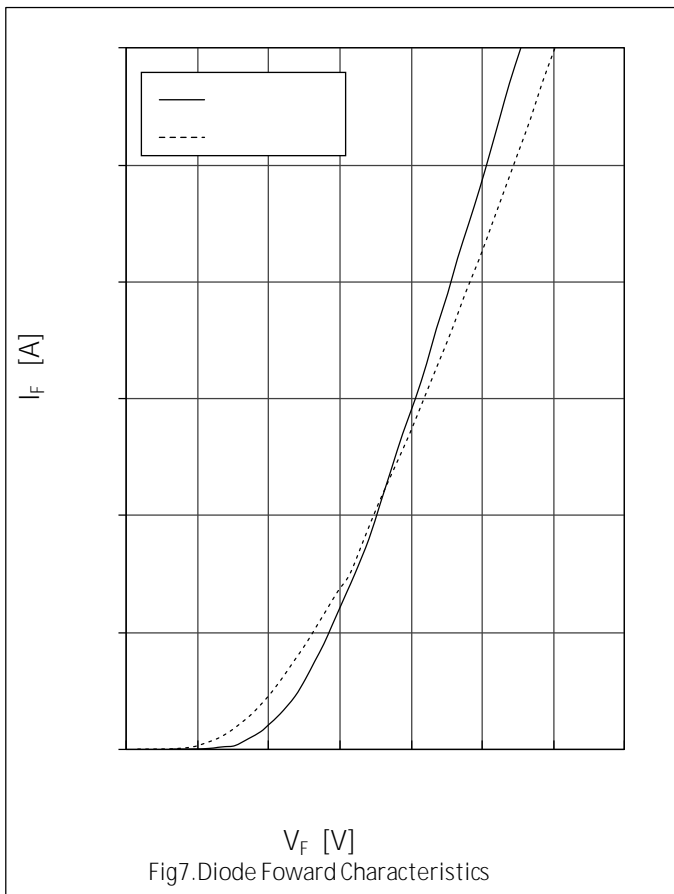
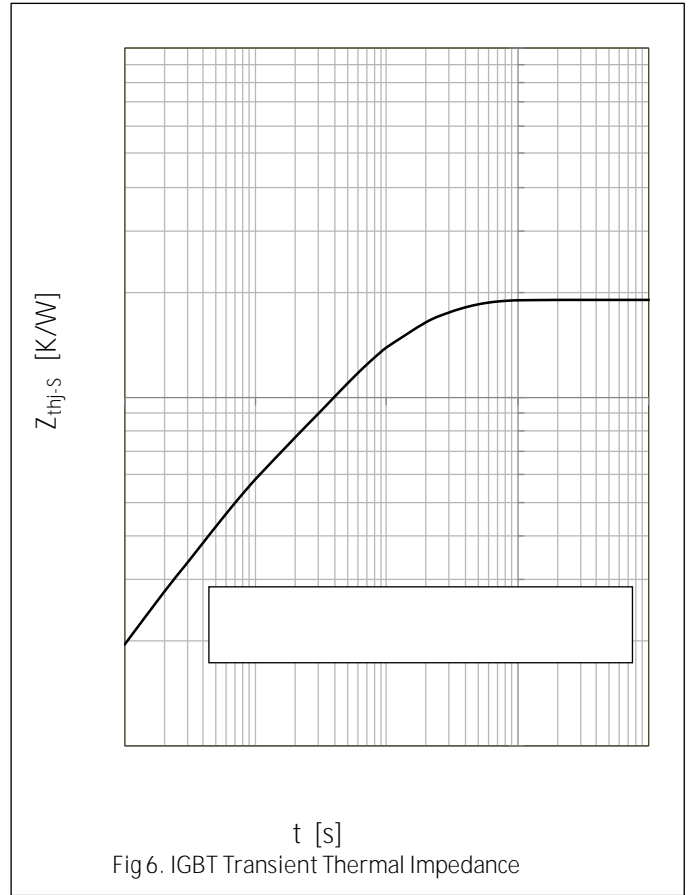
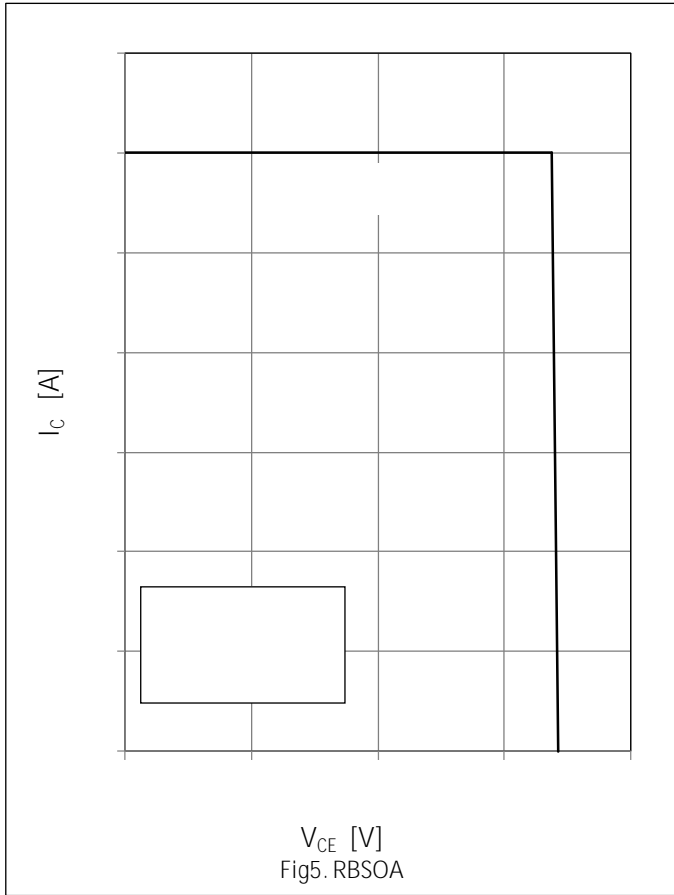

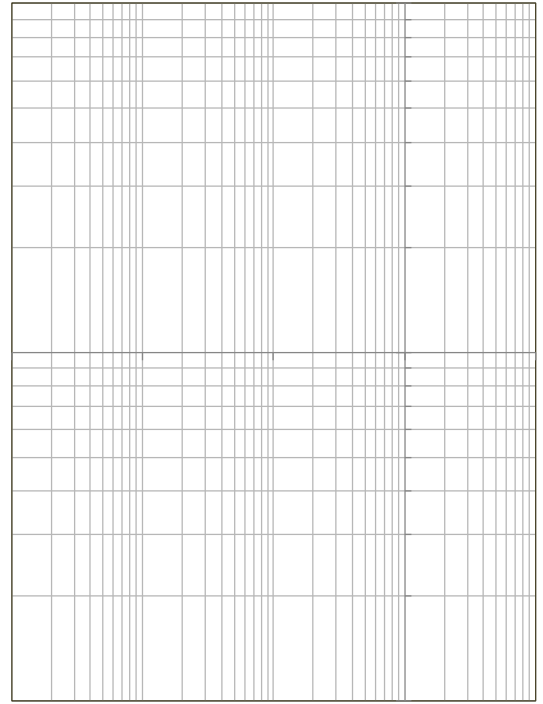
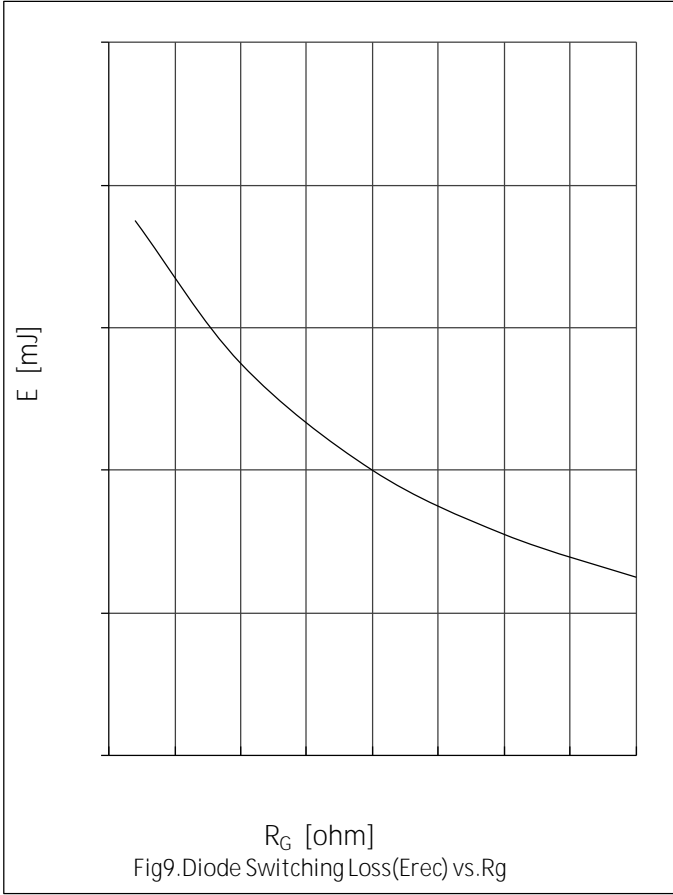

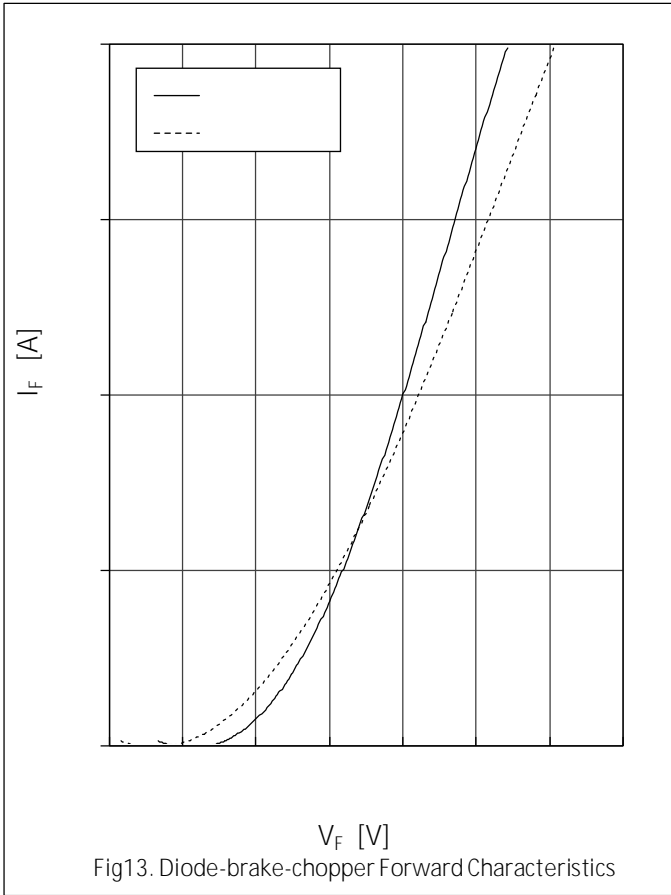



# MG15P12P3

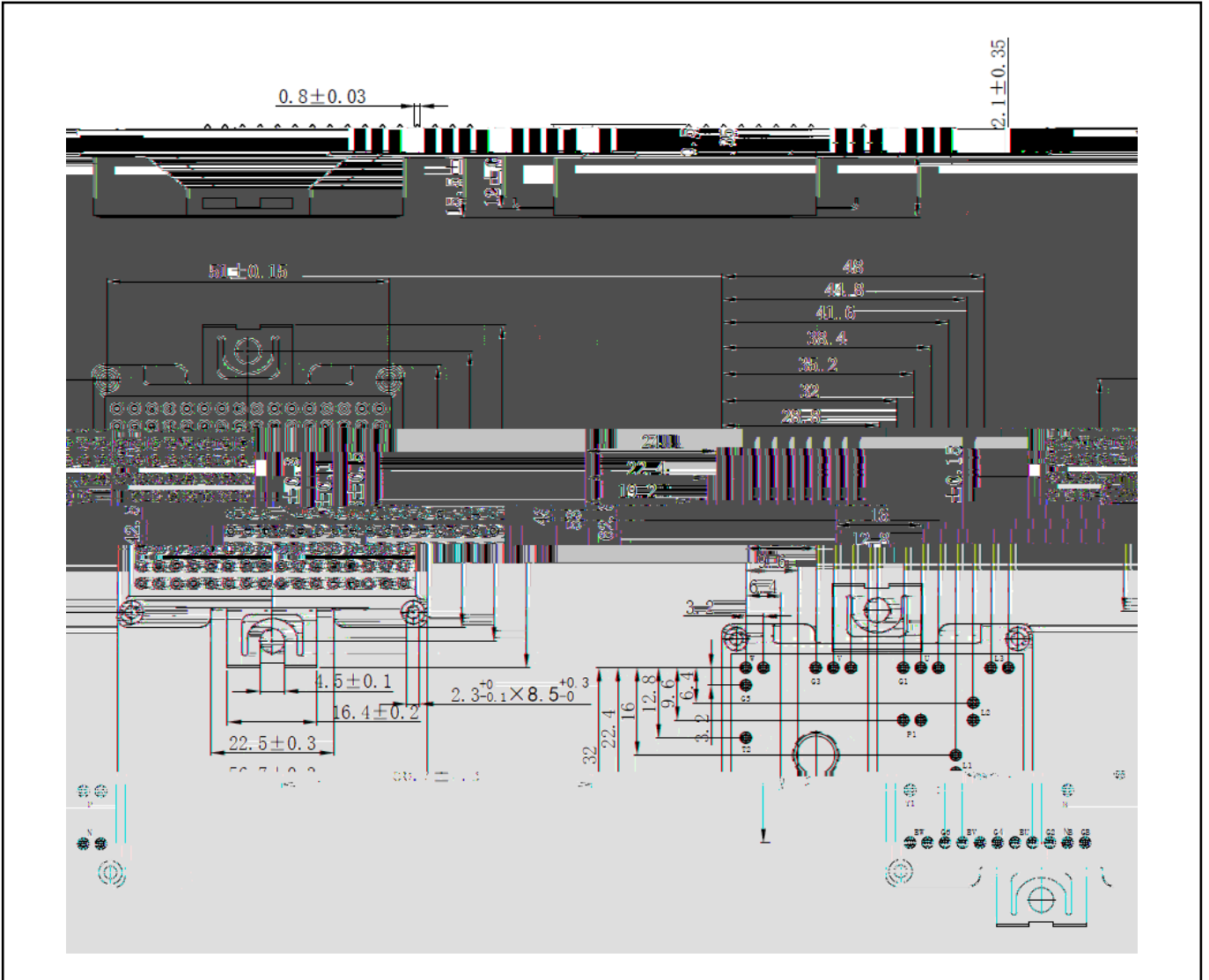
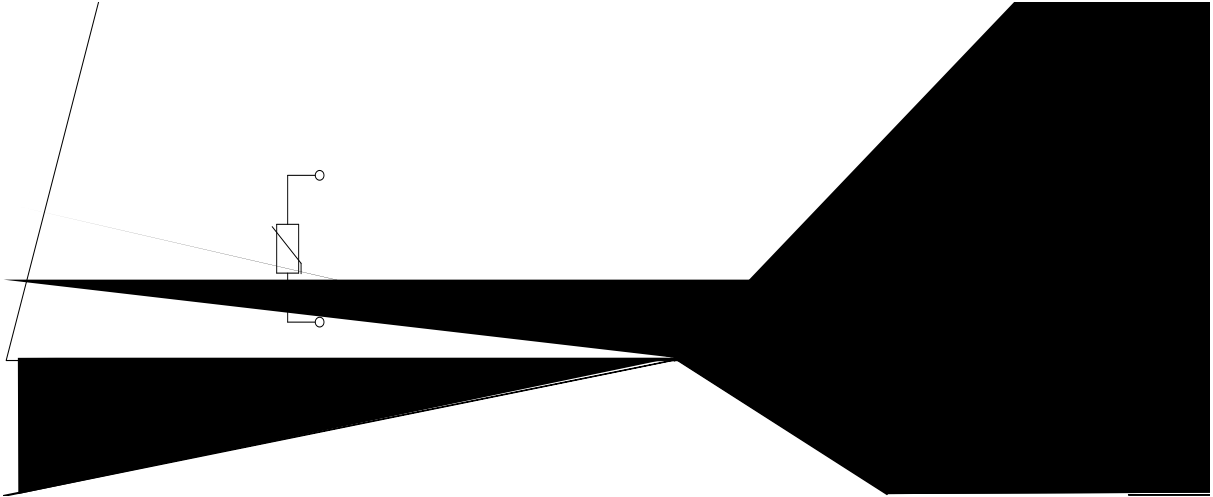



## Disclaimer

The information presented in this document is for reference only. Yangzhou Yangjie Electronic Technology Co., Ltd. reserves the right to make changes without notice for the specification of the products displayed herein to improve reliability, function or design or otherwise.

The product listed herein is designed to be used with ordinary electronic equipment or devices, and not designed to be used with equipment or devices which require high level of reliability and the malfunction of with would directly endanger human life (such as aerospace machinery, nuclear-reactor controllers, fuel controllers and other safety devices), Yangjie or anyone on its behalf, assumes no responsibility or liability for any damages resulting from such improper use of sale.

This publication supersedes & replaces all information previously supplied. For additional information, please visit our website [http:// www.frxelec.com](http://www.frxelec.com) , or consult your nearest Yangjie's sales office for further assistance.