



一级代理商：

深圳市弗瑞鑫电子有限公司

地址：深圳市宝安区西乡大道302号金源商务大厦B座三楼

frxelec

1. Feature



2. Description

3. Application Range

4. Functional Diagram

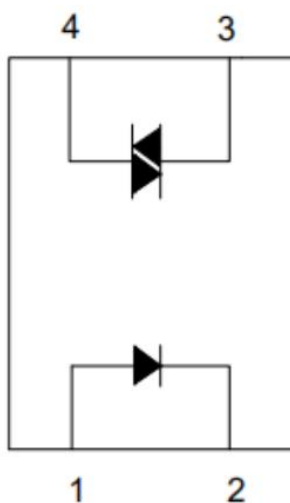

- 1. Anode
- 2. Cathode
- 3. Main terminal
- 4. Main terminal

5. Abol e Ma im m Ra ing (Ta=25)

Pa ame e		S mbol	Ra ed Val e	Uni

6. Electrical Optical Characteristics at Ta=25°C

Parameter		Symbol	Min	Typ.*	Max	Unit	Condition



7. O de Info ma ion

Pa N mbe

OR-M302X(L)-W-Y-Z

OR-M305X(L)-W-Y-Z

o **OR-M307X(L)-W-Y-Z**

No e

O ion	De c i ion	Packing an i

8. Naming Rule

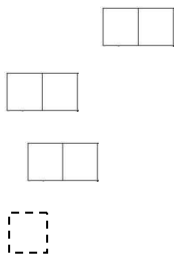
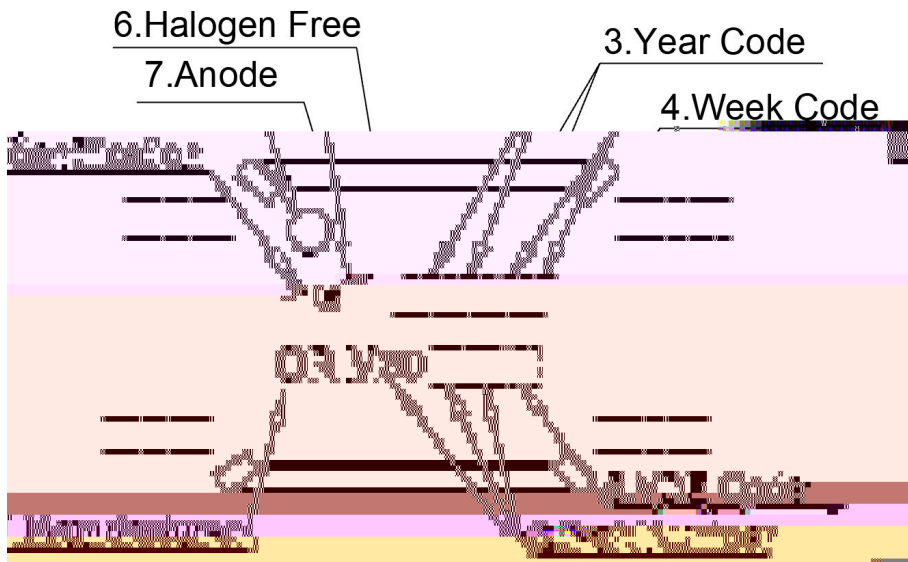

9. Package Dimension

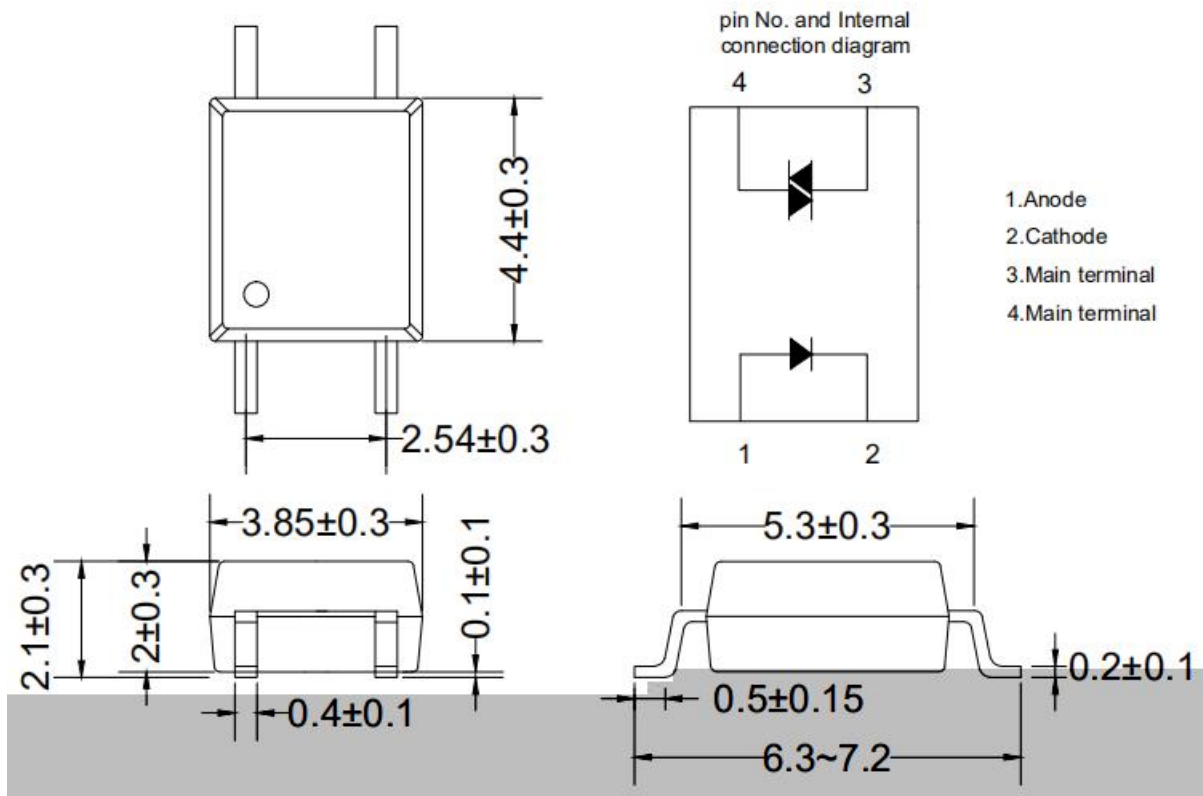

10. Recommended Foot Print Pattern (Mount Pad)

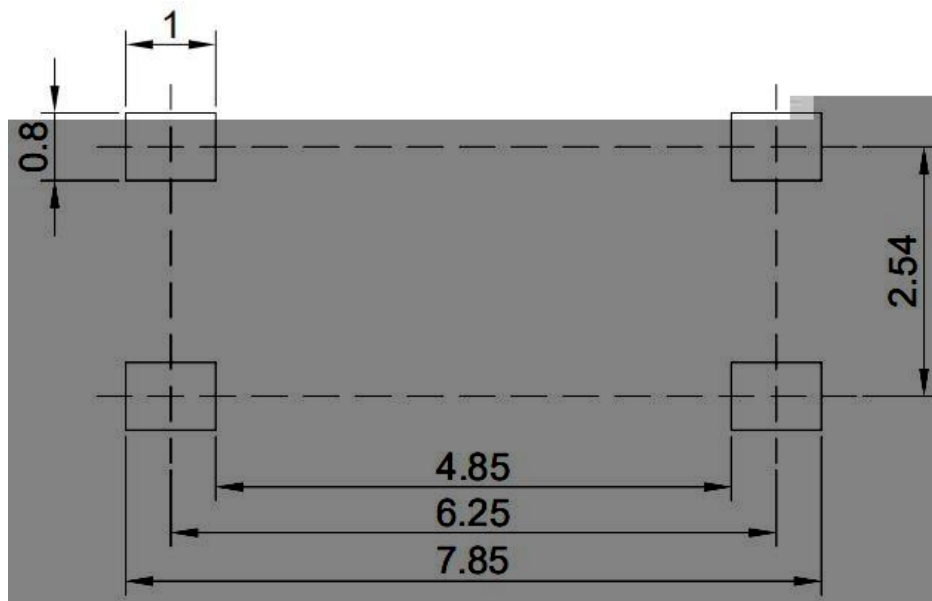

mm

11. Ta ing Dimen ion

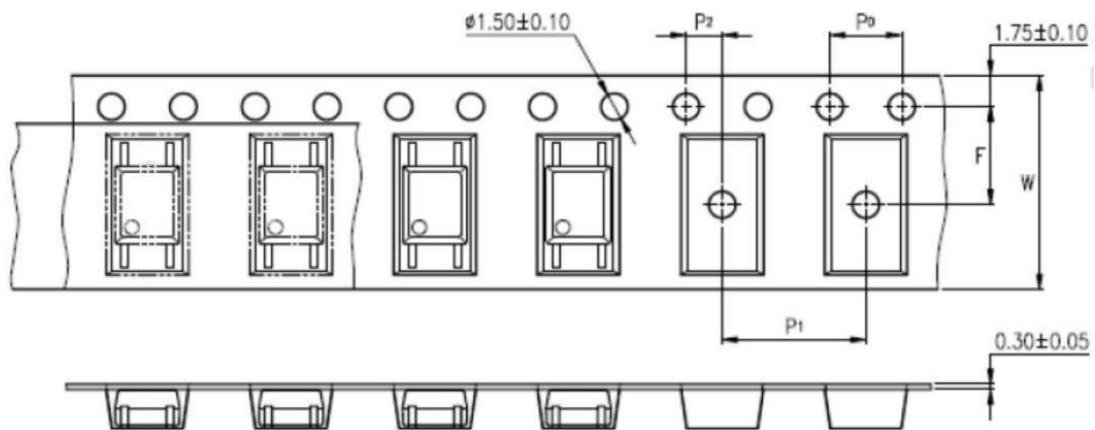
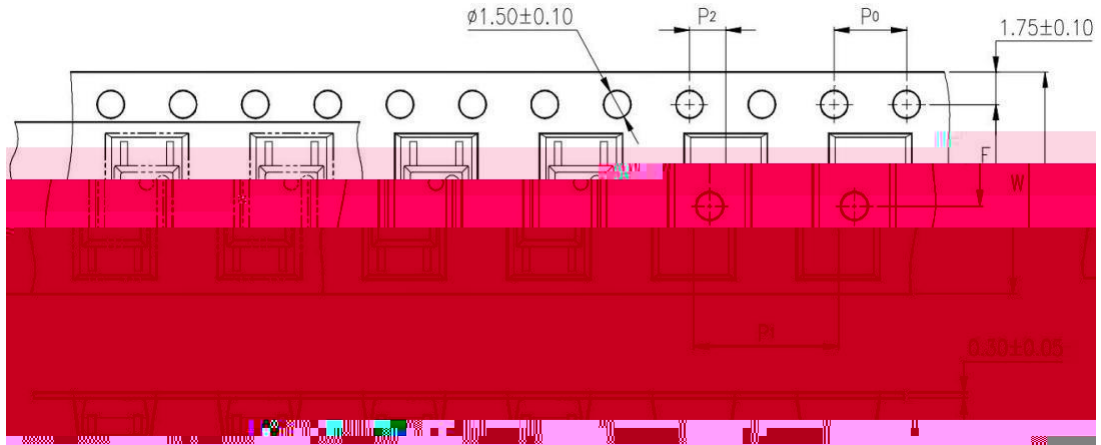

12. Package Dimension



Packing Information	



ORIENT
Shenzhen Orient
Components Co., LTD



Material Code : 120PCXXXXX

 P/N: OR-XXXXXX

 Lot No. : XXXXXX-XXXXX-TX-X

 D/C: XXXX

 Qty: XXXX PCS



内箱码

外箱码

“XXXXXXXXXXXXXXXX” (一体机序列码)
Made in China

No e

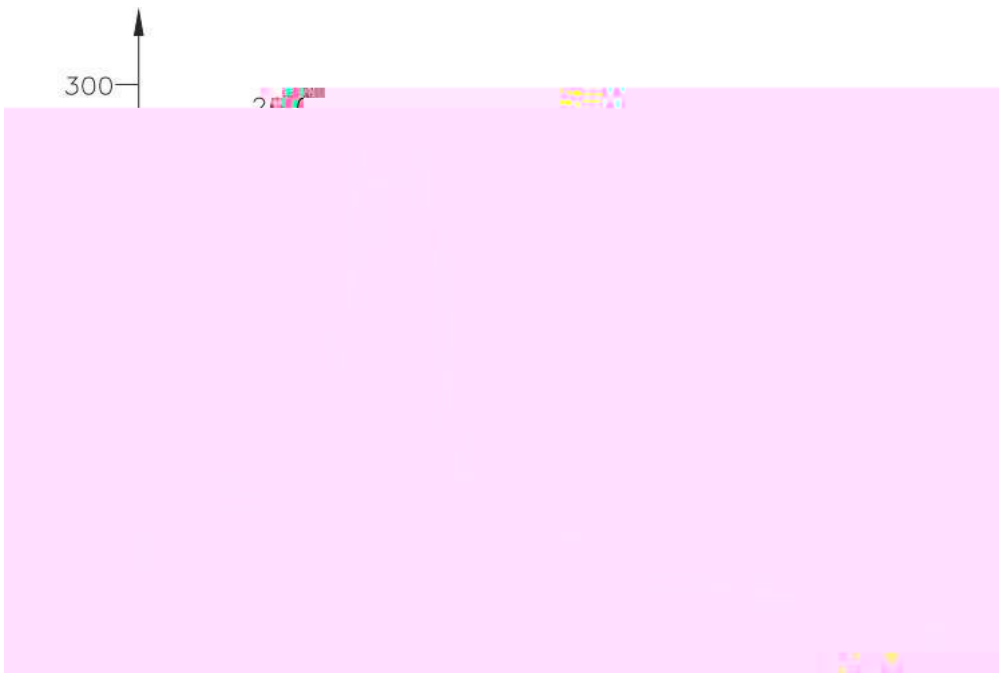



--	--

14. CHARACTERISTICS CURVES (TYPICAL PERFORMANCE)

Fig.1 Forward current vs Ambient temperature

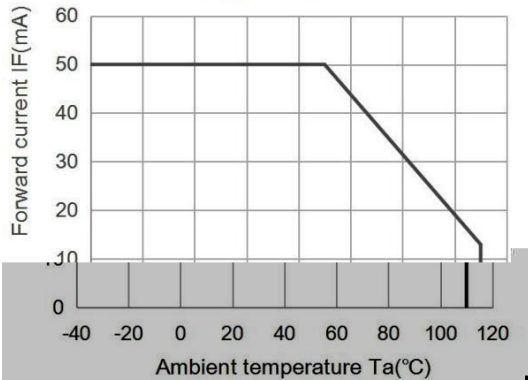

Fig.2 On-state current ITM (A) vs Ambient temperature

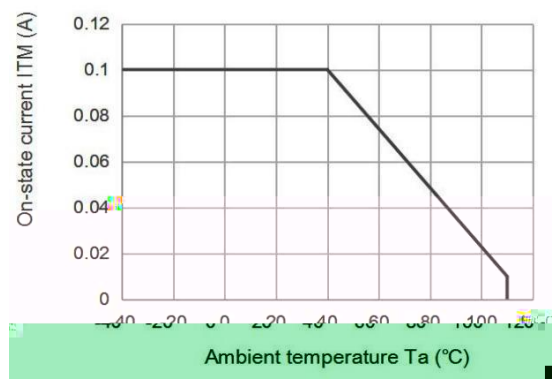

Fig.3 Minimum Trigger Current vs. Ambient temperature

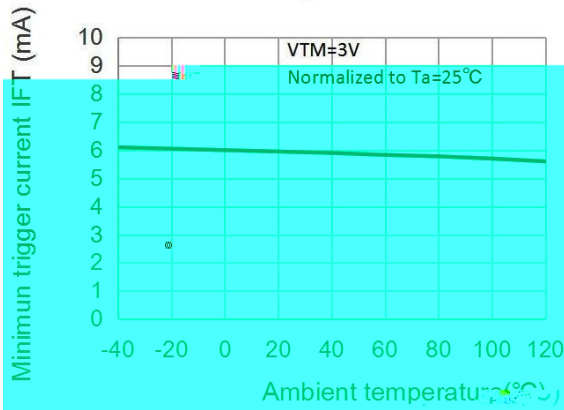

Fig.4 Forward current vs. Forward voltage

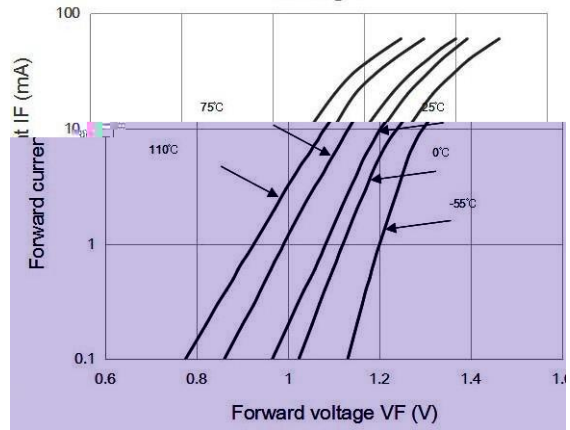

Fig.5 On-state voltage vs. Ambient temperature



Fig.6 Holding current vs. Ambient temperature

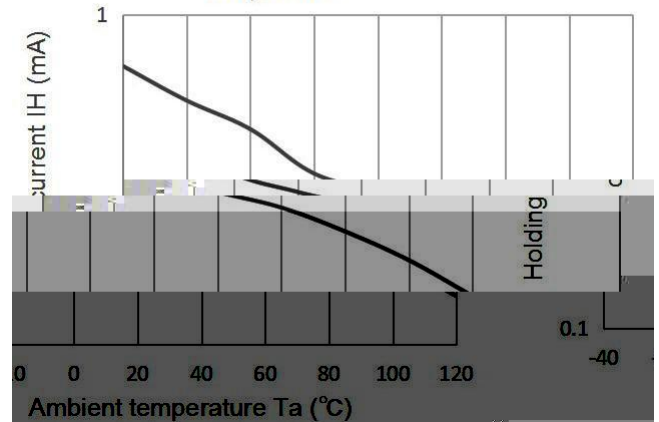

Fig.7 Repetitive peak off-state current vs. Temperature

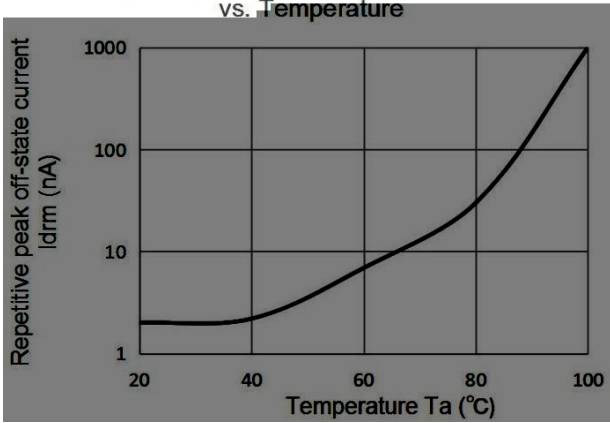
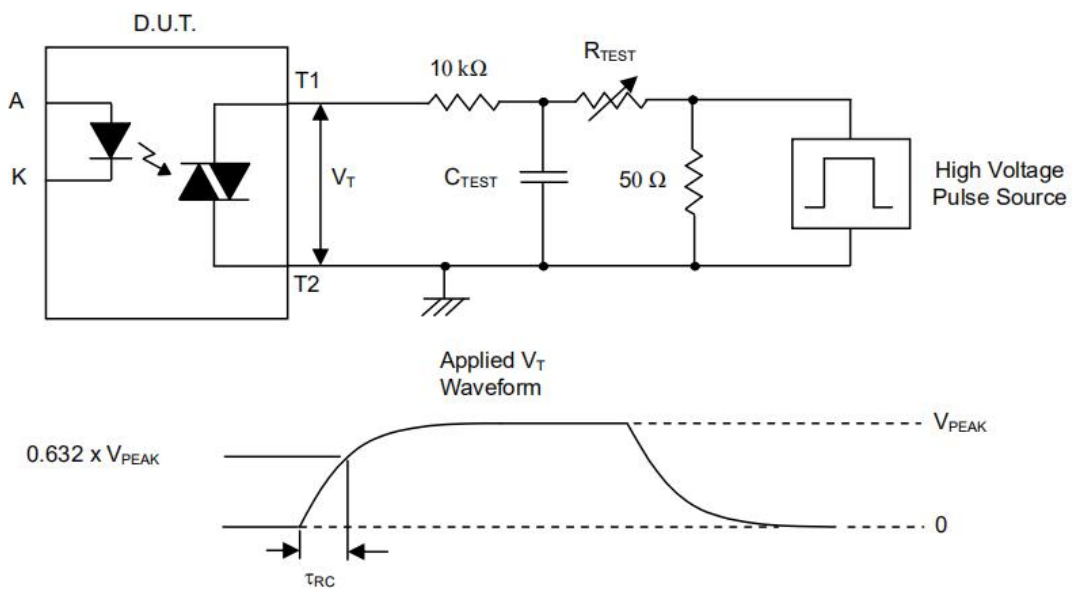
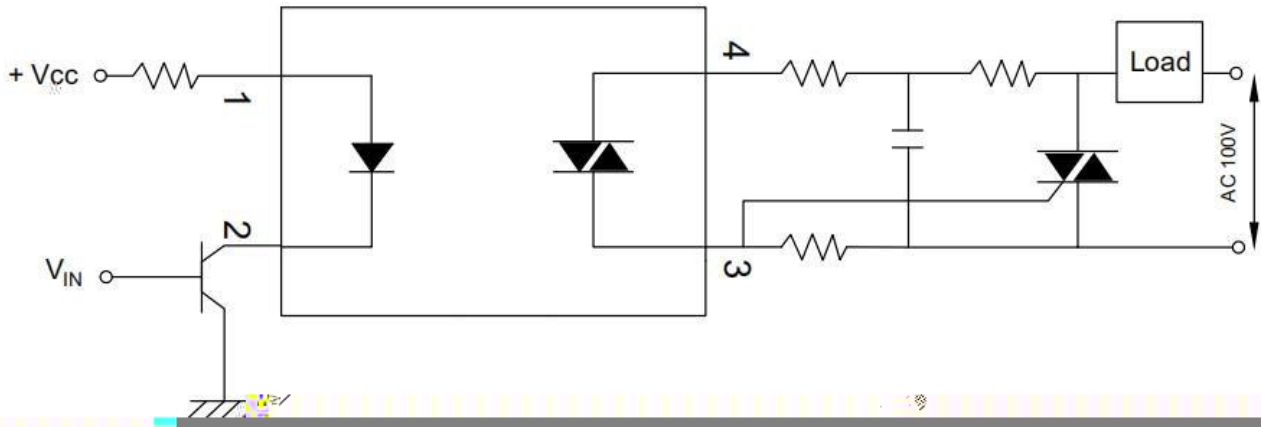
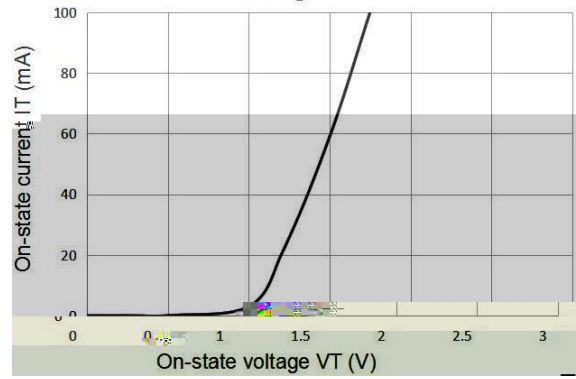

Fig.8 On-state current vs. On-state voltage



Measurement Method

